

TSUGAMI
AMERICA

BW209Z

CNC PRECISION AUTOMATIC LATHE

- 20mm Capacity Swissturn
- Independent Gang Slide
- 8 Backworking Tools
- Direct Drive Rotary Guide Bushing
- High Rigidity Bed
- FANUC 31i-B CNC Control

tsugamiamerica.com



BW209Z

9-AXIS INDEPENDENT GANG TOOL SWISS CNC LATHE

SPEED

- The BW209Z is chucker convertible and has the capability to use 3 tools in the cut, two on the main and one on the sub.
- The ability to preposition tools will allow you to optimize your cycle time. The horizontally opposed gang tool layout offers the shortest tool to tool path and therefore the quickest possible chip to chip time.
- The BW209Z has Y-axis, including 4 live tool positions on the sub spindle tool post, allowing milling operations traditionally performed on the main spindle to be carried out on the sub spindle internal to the cycle time.

ACCURACY

- Tsugami has a long-term reputation for machine accuracy. It all starts with their world-class engineering, incorporating symmetrically designed castings and an “A-frame” design of the gang slide. Utilizing the highest quality, motors, ball screws, rails and bearings assure precise motion control, and unique spindle cooling all work in concert and contribute to repeatable accuracy over the long life of the machine tool.

RIGIDITY

- Tsugami has the most rigid gang tool post in the industry due to opposing rail slides.
- Built on a heavy duty one piece cast iron base with thermally symmetrical construction, this machine features 0.1 micron axis resolution. A more rigid platform allows higher speeds and feeds.
- For extra peace of mind, the machines, motors, and FANUC controls are covered by an industry leading two-year parts and service warranty.

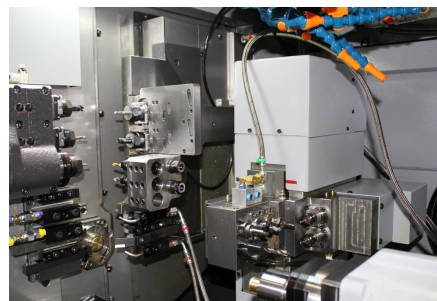

BW209Z Tool Zone

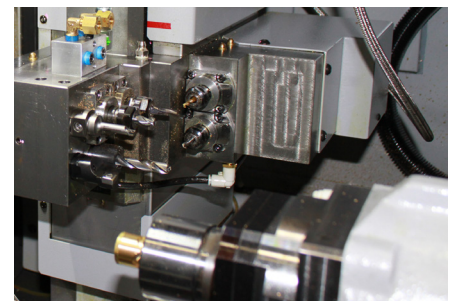

BW209Z Backworking Block

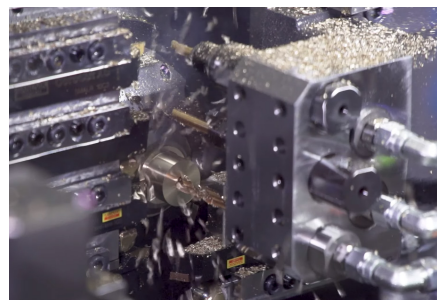

Superposition Control

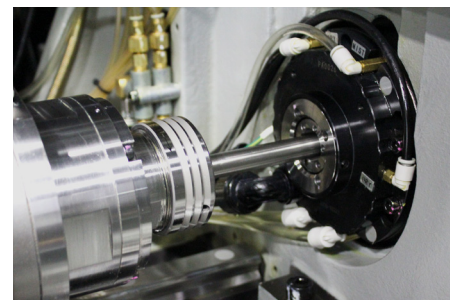

Servo Driven Guide Bushing

WORK ZONE & MODULAR TOOLING

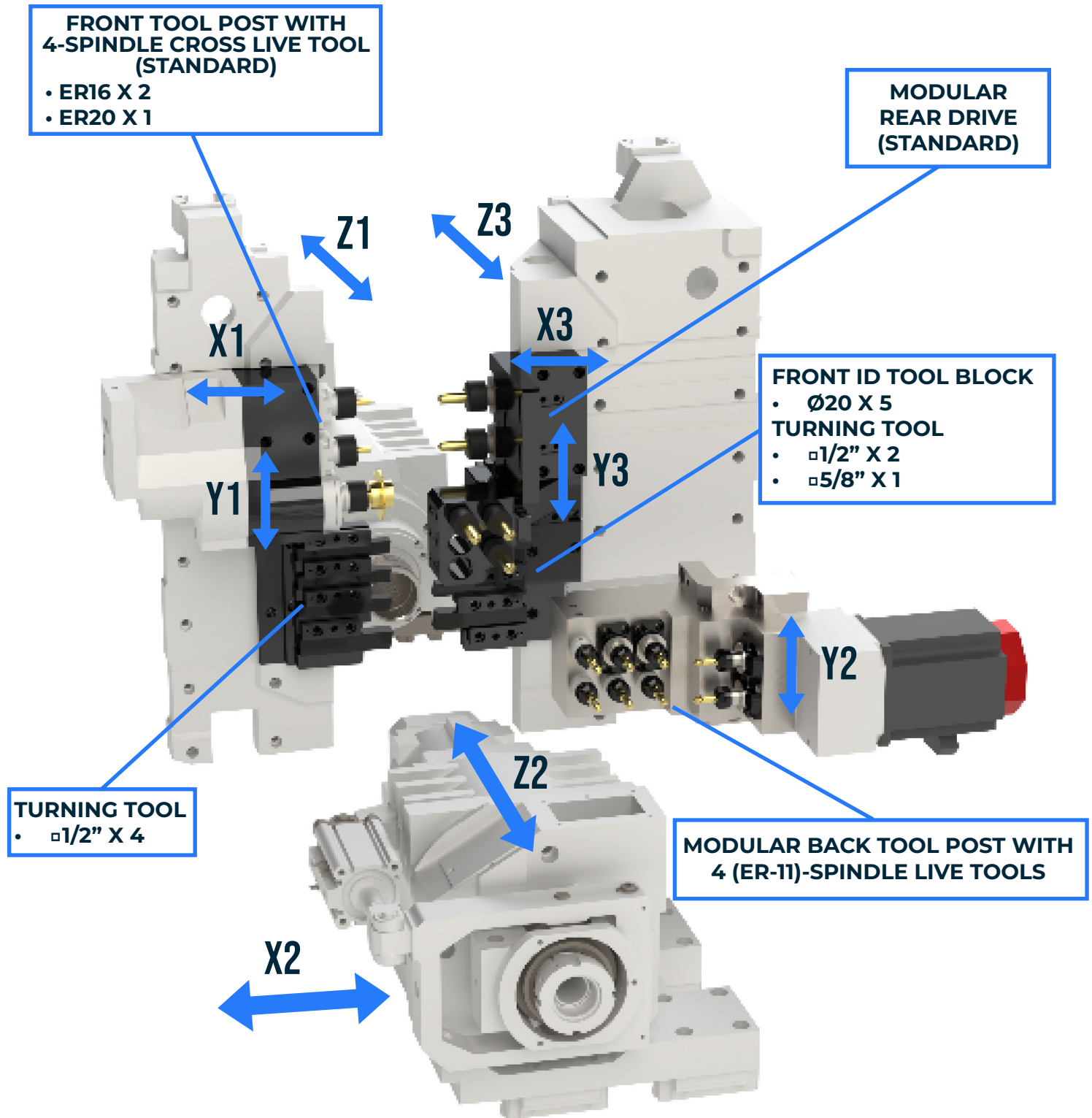

CHUCKER CONVERTIBLE

The BW209Z can be changed over in minutes. Adding a Chucker Kit allows you to convert your BW209Z from a traditional sliding headstock Swiss function to standard lathe-type chucker mode. This allows you to run high precision parts utilizing standard drawn barstock. Other benefits include shorter remnant, better concentricity and more. This quick-change flexibility makes these machines ready to tackle whatever job comes in the door.

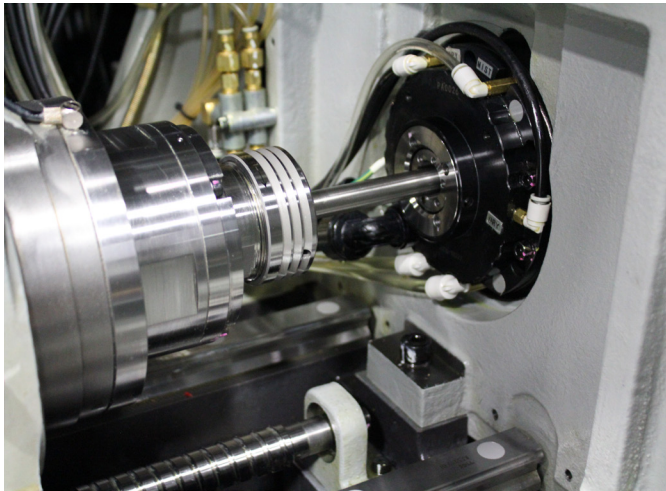

Running in Swiss Mode

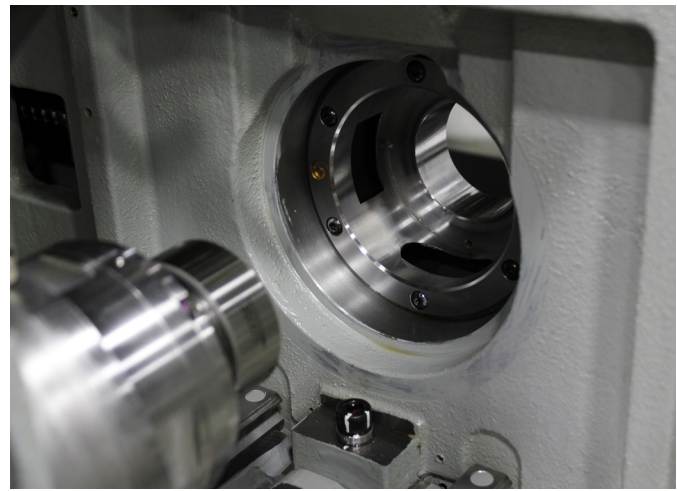

Running in Chucker Mode

NEED SOMETHING CUSTOM?

From the machine Make Ready process, to integrating mechanical and robotic loading and unloading systems, to custom tool creation and spindle repair, IMG is dedicated to supporting all Tsugami users in North America!



Grinding Room



Make Ready Facility



Milling Room

OSCILLATION CUTTING

Oscillation Cutting is a technological breakthrough that oscillates a servo axis to help break chips in tough to cut materials, reduces heat in the cut, while not diminishing tool life.

- Productivity is increased by significantly reducing operator interruption to remove hanging or bird nesting chips.
- Easy to program by special G code
- Oscillation parameters can be changed easily within the program for machining multiple features with multiple tools.
- Can be used for many machining operations including OD turning, drilling, boring, grooving, cutoff, circular interpolation, and most FANUC canned cycles.

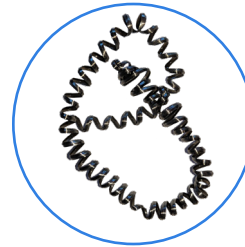

**WITHOUT
OSCILLATION**

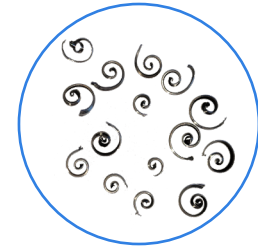

**WITH
OSCILLATION**

AVAILABLE ON ALL PATHS

ABILE SOFTWARE

- Developed by Tsugami, Abile is capable of programming moderately complex machined parts. Abile incorporates all basic machines featured and several material types with predetermined feed rates.
- Abile allows first time users to quickly become proficient with Swiss processing despite having limited knowledge. Abile comes free with your machine purchase and requires no license fees, maintenance agreements, or seat limitations.
- Abile allows you to generate a 2 or 3-path part program, complete, with specific and editable codes in standard FANUC G Code format. Abile automatically generates machine process and provides component run times.

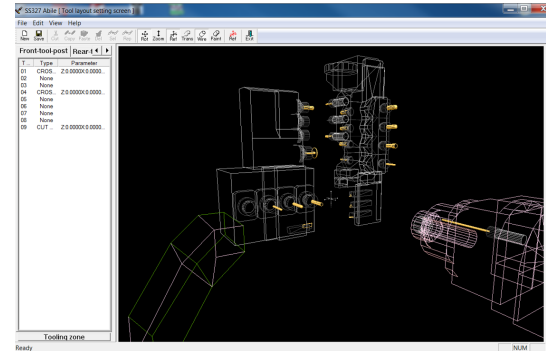

Program Generator

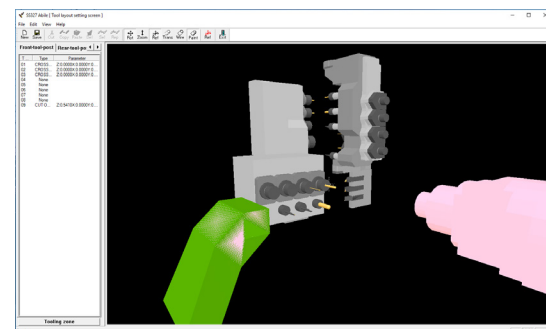

Tool Setting

MACHINE STANDARD SPECIFICATIONS

ITEMS

BW209Z

MACHINING RANGE

Working Barstock Diameter	Ø3 to Ø20 mm (.12 to .79 in.)
Max. Machining Length	170 mm (6.69 in.) (Direct-drive rotary guide bushing), 45 mm (1.77 in.) (Chucker Mode)
Max. Main Spindle Drilling Diameter	Ø10 (.39 in.)
Max. Main Spindle Tapping Diameter	M10
Main Spindle Through ID	Ø32.5 mm (1.27 in.)
Max. Back Spindle Chucking Diameter	Ø20 mm (.79 in.)
Max. Back Spindle Drilling Diameter	Ø8 mm (.31 in.)
Max. Back Spindle Tapping Diameter	M8
Max. Cross Drilling Diameter	M5 x 0.8
Max. Cross Tapping Diameter	M6 (Front tool post/Rear tool post/Back tool post)
Max. Tool Spindle Slotting Cutter Diameter	Ø45 mm (1.77 in.)
Max. Back Drilling Diameter	Ø6 mm
Max. Back Live Tapping Diameter	M5

MACHINING CAPABILITY

Main Spindle Speed	200 to 10,000 rpm
Back Spindle Speed	200 to 12,000 rpm
Rotary Guide Bushing Speed	200 to 8,000 min-1: Carrier type rotary guide bushing, 200 to 10,000 min-1: Direct-drive guide bushing
Cross Tool Spindle Speed	200 to 8,000 rpm min-1
Tool Size	.5 in x .5 in square (T04,T05,T06,T07, T16,T17), .625 in x .625 in square (T18)
Rapid Traverse Rate	32 m/min (Z1, Z2, X2) 24m/min (Y1, Y3) 15 m/min (Y2) 12 m/min (X1, X3, Z3)
Controlled Axes (liner axes)	9

MOTORS

Main Spindle	2.95/4.96 HP (2.2/3.7 kW)
Back Spindle	2/2.95 HP (1.5/2.2kW)
Axis	0.67 HP (0.5 kW)
Cross Drill	1.34 HP (1.0 kW)
Coolant Pump	1.34 HP (1.0 kW)
Lubricating Oil Pump	3W

OTHER

Net Weight	6,393.4 lbs (2,900 kg)
Power Source Requirement	15.4 kVA
Compressed Air Requirement	0.4 Mpa or above
Air Discharge Rate	50 NL/min
Coolant Tank Capacity	180 L / 47.5 Gal
Width x Depth x Height	79.13 in. X 59.25 in. X 68.90 in. (2,010 mm x 1,505 mm x 1,750 mm)

NC SPECIFICATIONS

ITEMS

BW209Z

NC Unit	FANUC 31i-B
Controlled Axes	X1, Y1, Z1, X2, Y2, Z2, X3, Y3, Z3, C1, C2
Least Input Increment	0.0001 mm (X1/X2/X3-axis in diameter)
Least Command Increment	0.0001 mm (X1/X2/X3-axis in diameter)
Maximum Programmable Value	± 8 digits
Interpolation Method	Linear, circular, helical, polar, cylindrical
Feedrate Function	1 to 6,000 mm/min
Feedrate Override	0 to 150%, 10% step
Dwell	G04 0 to 99999.999
ABS/INC Command	X, Z, Y, C: Absolute U, W, V, H: Incremental
Tool Offset Pairs	Sum of all paths: 192
LCD/MDI	10.4" color LCD
Display Language	English
Part Program Storage Size	Sum of all paths: 64 kbytes (equivalent to 160 m)
Registrable Programs	Sum of all paths: 63
Miscellaneous Functions	M5-digits
Spindle Function	S5 digits
Tool Function	T4 digits

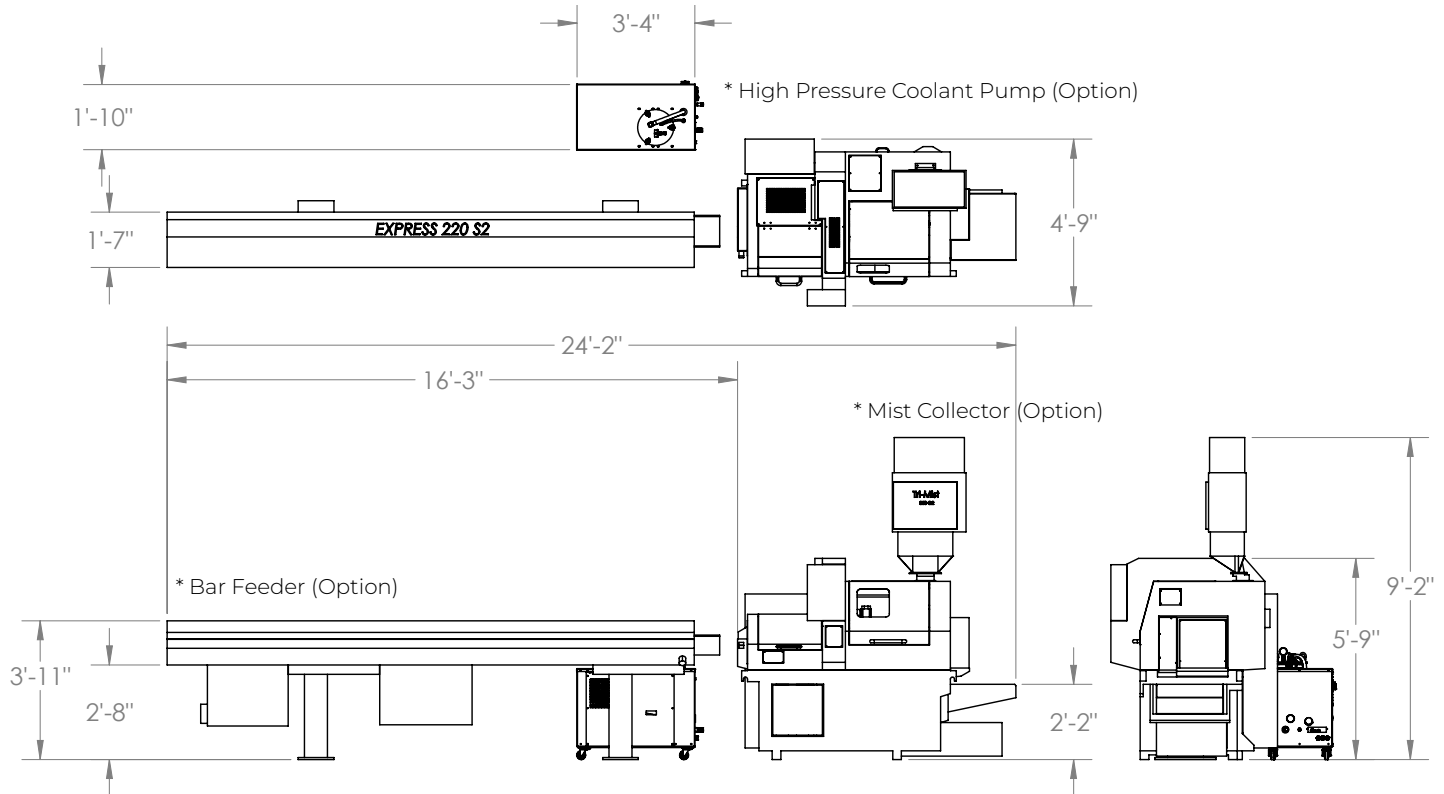

Since 1978, Tsugami America (formerly known as Tsugami/Rem Sales) has been the exclusive source for Precision Tsugami CNC machine tools in North America. Headquartered in Windsor, CT, Tsugami America provides machine tools and engineering expertise through an extensive network of authorized distributors and technical centers. Technical support and customer service are available throughout North America. Our distributors' trained service personnel provide technical support throughout the long life-cycle of our Tsugami machine tools, and work hand-in-hand with Tsugami America's engineers to deliver common-sense solutions to everyday problems.

Our application engineers help customers tackle and solve the toughest high-precision manufacturing challenges, on-time and on-budget. We have a 40-year history and reputation of serving the needs of small parts manufacturers in North America with the highest level of expertise and customer care. Our industry-respected, knowledgeable staff is comprised of both long-time employees and fresh faces all who share a commitment to provide you, our customers, with the competitive advantage to "do more with less" every day.

DISTRIBUTION NETWORK

The Robert E. Morris Company

Serving: CT, MA, RI, NH, VT, ME, NY, NJ
www.robertemorris.com

Morris Midwest Wisconsin & Illinois

Serving: WI, IL, MI Upper Peninsula
www.morrismidwest.com

Methods & Equipment Associates

Serving: MI
www.methods-equipment.com

Ellison Technologies

Serving: WA, OR
www.ellisontechnologies.com

MAQUIPRIME

Serving: Mexico
www.maquiprime.com.mx

Morris South

Serving: NC, SC, GA, VA, AL, MS, TN, AR, FL
www.morrissouth.com

Precision 360

Serving: FL, PA, NJ, DE, MD, CA, Northern NV
www.precision360.com

Technical Equipment Sales Co

Serving: OH, IN, KY
www.techequip.com

Hartwig, Inc.

Serving: MO, IL, IA, KS, CO, OK, TX, LA, MT, UT, NM, ID, WY
www.hartwiginc.com

Morris Midwest Minnesota

Serving: MN, ND, SD
www.morrismidwest.com

Morris Great Lakes

Serving: NY, PA, WV
www.morrisgreatlakes.com

Arizona CNC

Serving: AZ, NV
www.arizonacnc.com

EMEC Machine Tools Inc.

Serving: Eastern Canada
www.emecmt.com

Thomas Skinner

Serving: Western Canada
www.thomasskinner.com

TSUGAMI AMERICA LOCATIONS

WINDSOR, CT

651 Day Hill Road
Windsor, CT 06095

FORT WAYNE, IN

4501 Earhart Drive, Suite B
Fort Wayne, IN 46809

BROOKLYN PARK, MN

9495 Winnetka Avenue N, Suite 100
Brooklyn Park, MN 55445

FULLERTON, CA

1521 E Orangethorpe Ave, Suite E
Fullerton, CA 92831

860-687-3400 | www.tsugamiamerica.com | info@tsugamiamerica.com

TSUGAMI AMERICA IS ISO 9001:2015 CERTIFIED QMS