

PRECISION TSUGAMI

TSUGAMI

CNC Precision Automatic Lathe
SUPER SWISSTURN

SS26/SS32/SS32L

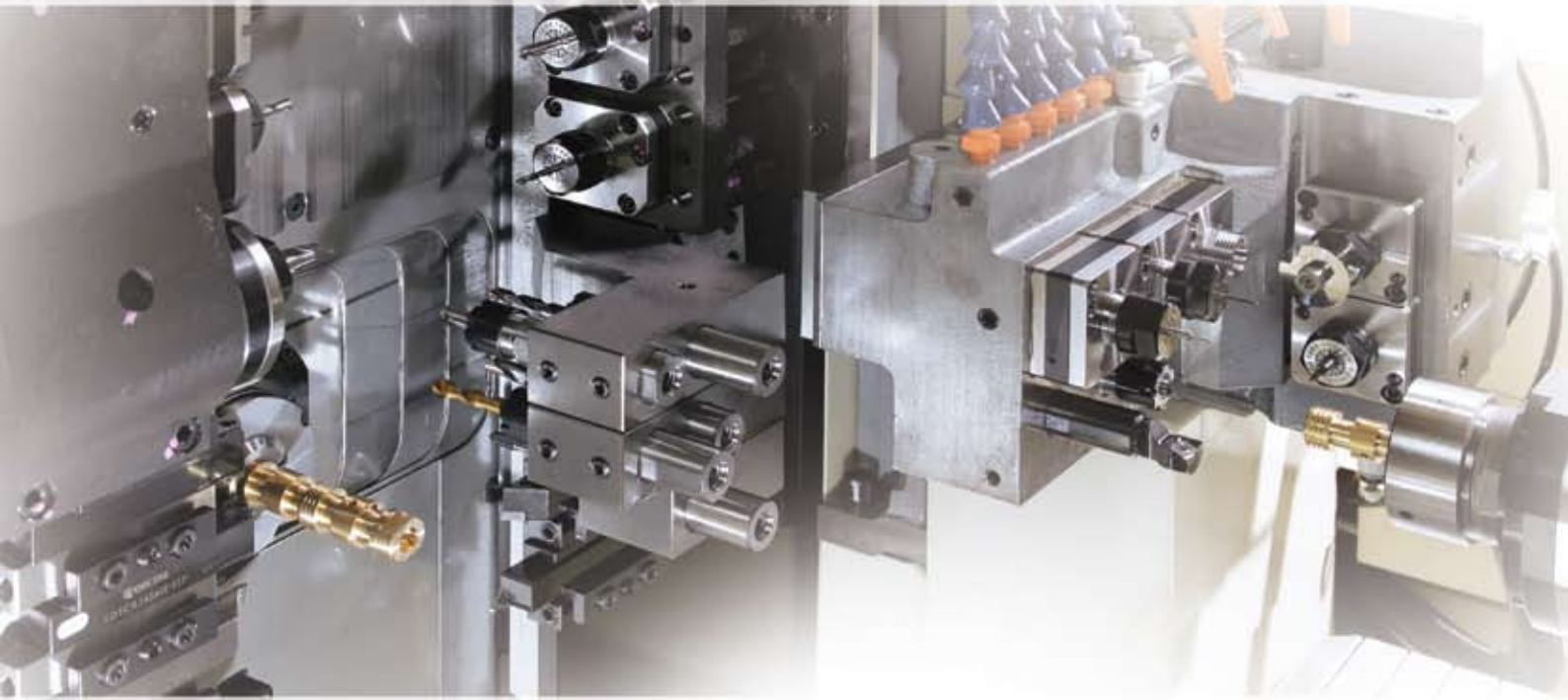

Opposed gang tool combination machine
Modular tool zone effectively handles complex parts
Ideal for short run or extended production.



Highly capable tool zone enables simultaneous machining

Wide tooling zone

Long stroke rotary guide bushing

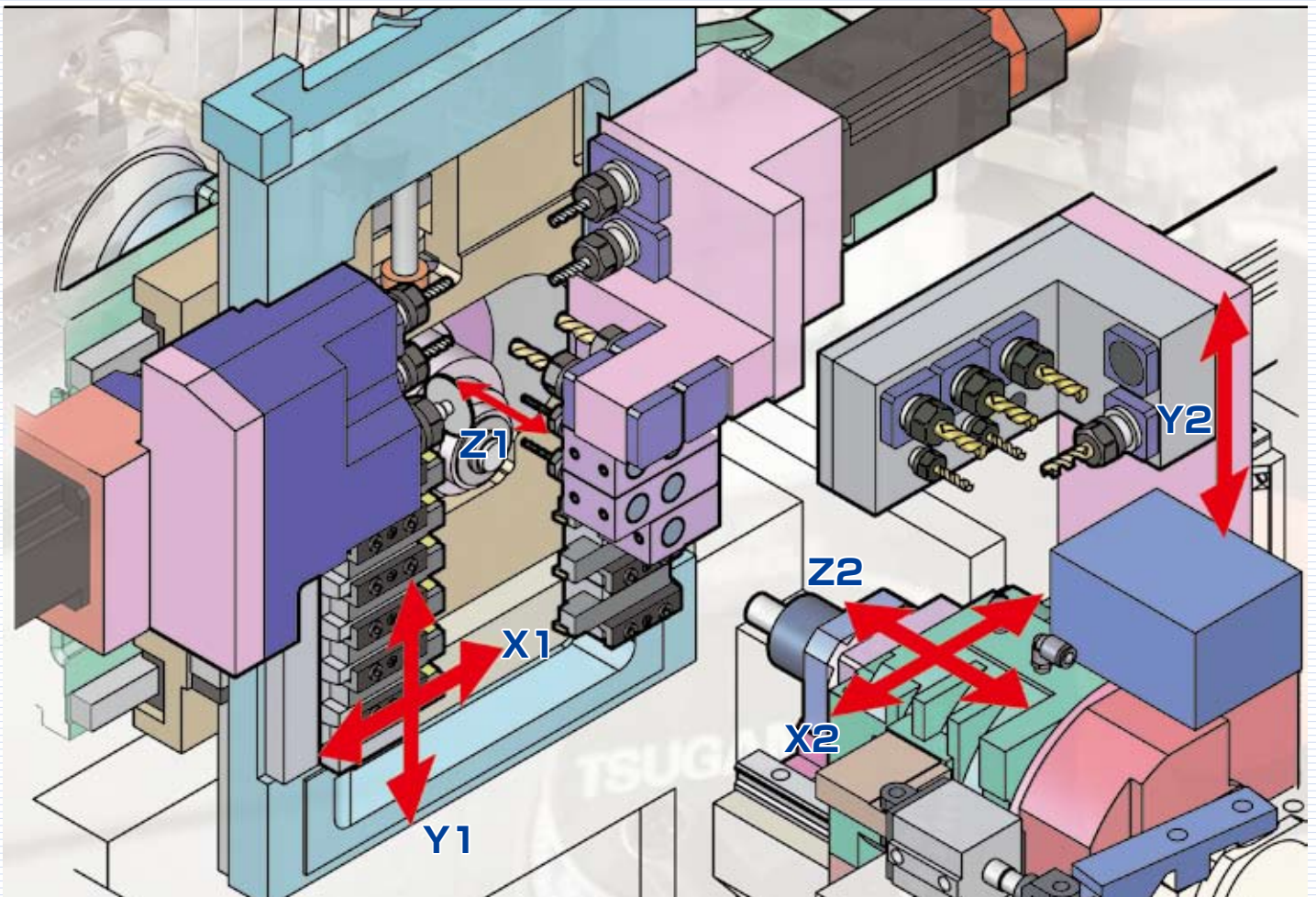



Simultaneous operation of main and sub spindle.

(Y-axis back tool post with cross tool spindle shortens drastically the cycle time)

- Back slitting
- Vertical traverse milling with back endmill
- Back cross drilling and cross tapping
- Deburring of front cross drilled holes

Machining example

Cycle time reduction

Conventional machine **105sec**

SS26/32 **85sec**

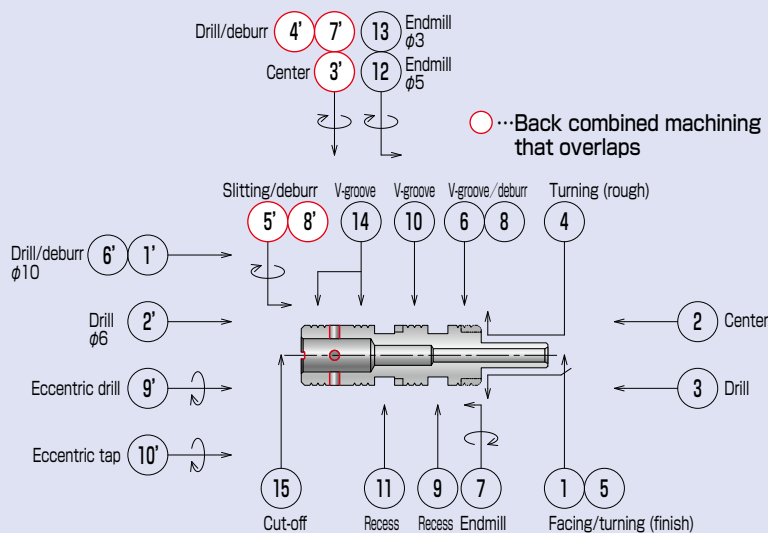
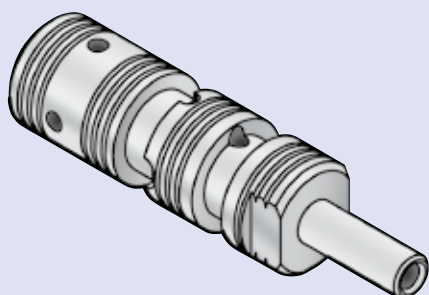

"Extremely Capable" machine excels in controlling costs by "reducing idle time" and "maximizing productivity"

Tools on the rear tool post and back tool post can be freely laid out according to the workpieces.

Modular Tooling

A combination of rotary tools, internal tool holders, and turning tool holders

- Cross rotary tools
- Front rotary tools
- Fixed drill holders (double/single)
- Turning holder

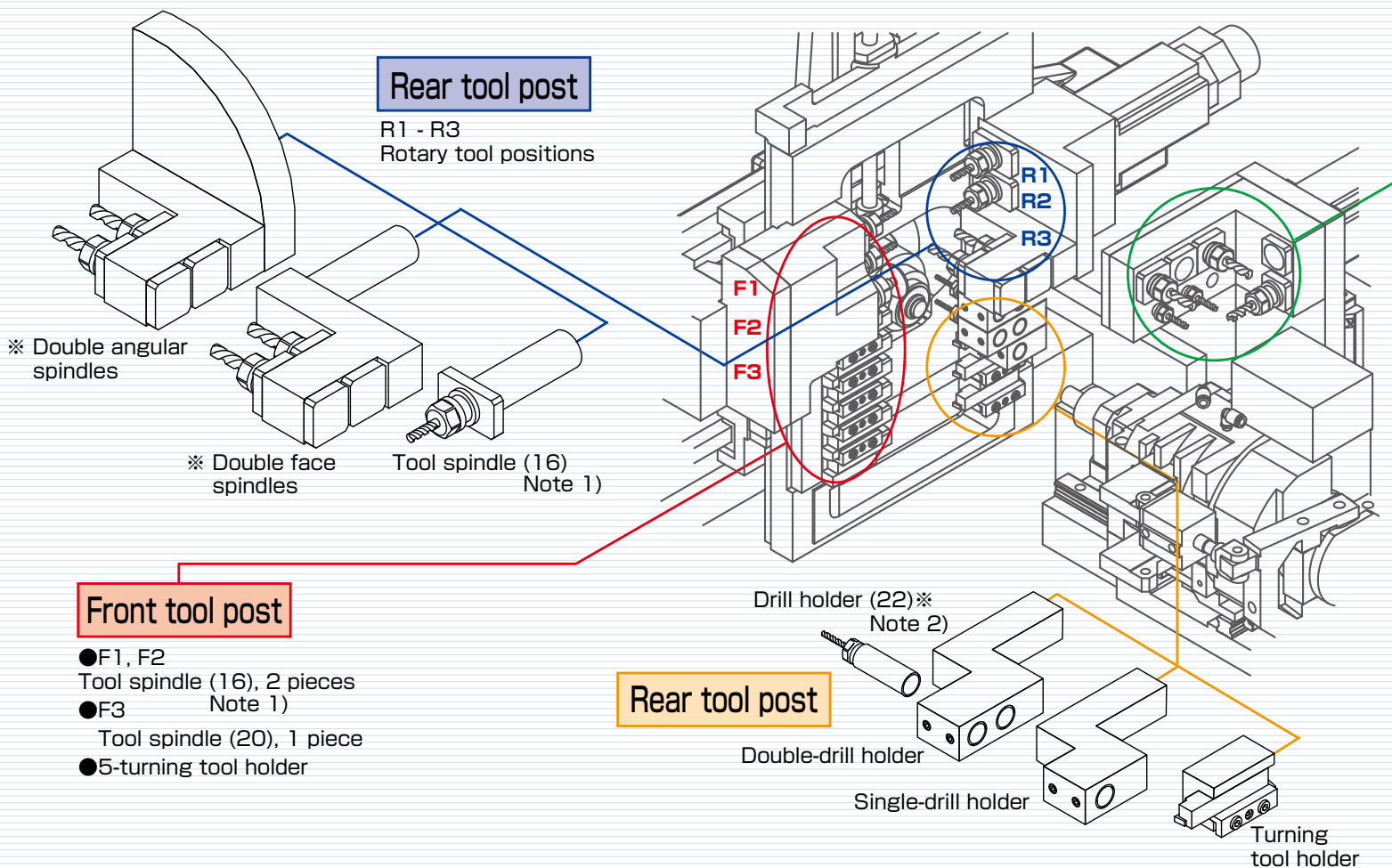

Standard tooling specifications

Tool post	Name	Quantity
Front tool post	Tool spindle (16)	2
	Tool spindle (20)	1
	5-turning tool holder	1
Rear tool post	Tool spindle (16)	3
	Double-drill holder	2
	Single-drill holder	1
	Turning tool holder	2
Back tool post	Tool spindle (16)	3
	Back adapter	2

Tooling accessories

	Main spindle collet chuck	Back spindle collet chuck	Rotary guide bushing
SS26	2601-1196 (S25)		2621-1196 (S25)
SS32	2601-5216 (BS32)		2621-6216 (BS32)
SS32L			—

Main spindle, back spindle adapter: Standard
Rotary guide bushing: Optional



makes flexible layout possible according to the workpieces.



Back tool post

B1 - B5
Rotary tool positions

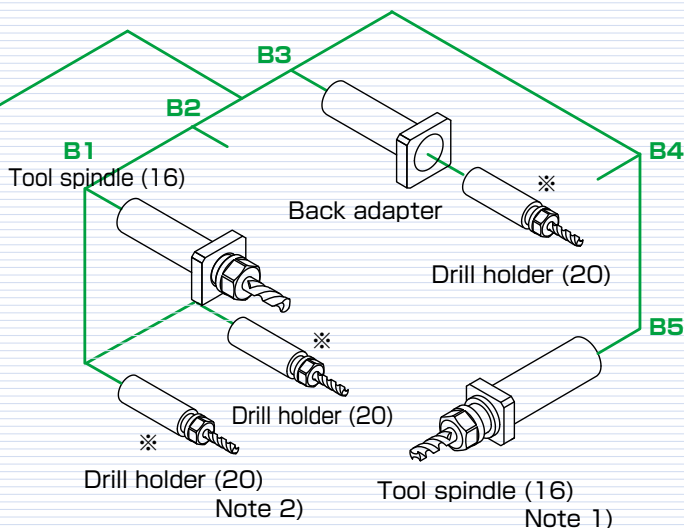

※Optional

Note 1) 16: AR16 collet 20: AR20 collet

Note 2) 22: Shank diameter 22 (AR16 collet)
20: Shank diameter 20 (AR16 collet)

Highly Efficient Machining

- Turning capability equivalent to the "double spindle"
- Cartridge type thick tool spindle provides powerful combined machining



Wide Tooling Zone

- Easy tooling setup
- Easy front discharge of even long workpieces
- Easy chip disposal

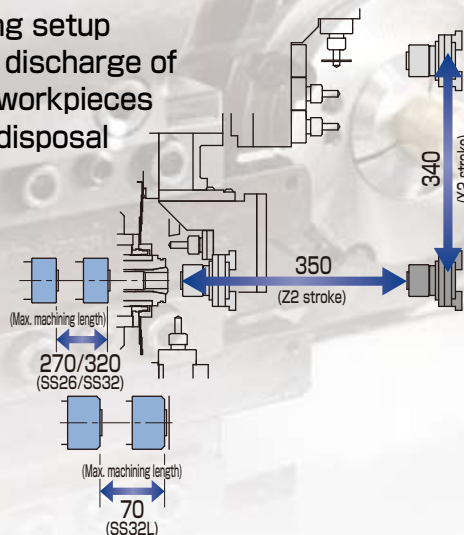

Long Stroke Rotary Guide Bushing (optional)

- SS26: 270 mm SS32: 320 mm
- Guide bushing adapter: Front installation
- Guide bushing clearance: Front adjustment

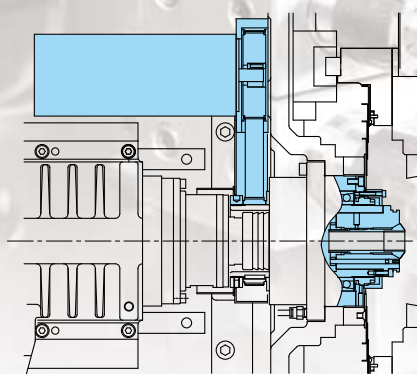

Simultaneous Machining Shortens Cycle Time

■ Back spindle and dedicated back tool post enable a front and back complete overlapped machining.



Guide bushing type or guide-bushing-less type selectable according to the workpiece **SS26**

- Possible to switch between the guide bushing type and guide-bushing-less type so the most suitable operation for the workpiece length can be chosen.
- The spindle without a guide bushing does not require ground bars, enabling high speed and high precision when machining cold drawn bars. (When the guide-bushless kit is attached, machining capabilities depends on the material and the conditions of cutting.)

Extended Unmanned Operation

- Large capacity chip pan in wide tooling zone enables a long time unmanned operation.

Optimize Programs with SS Abile Software (optional)

A program of optimum tooling and cycle time for multiple-path and multiple-spindle controls of even complicated shape can be easily created.

Anyone can create a high grade and standardized program for high precision sophisticated workpieces based on TSUGAMI's machining know-how (including machining processes and cutting conditions), taking the best matching of machine and software into account.

Tooling

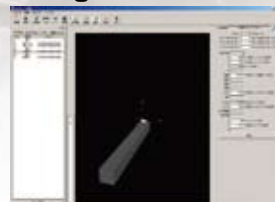

3D simulation

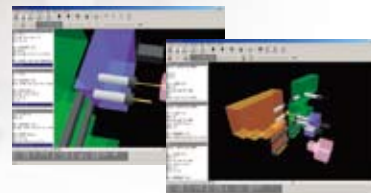

3D simulation can check the main spindle and back spindle machining at any angle.

Options

	Name		Name
Guide bushing	Rotary guide bushing	Workpiece discharge system	Work catcher
	Rotary guide bushing adapter		Work conveyor
	Guide-bushing-less kit (SS20)		Front discharge unit
High function system	Back spindle C axis	Chip disposal	Rear discharge unit
	Back spindle 15° indexing		Chip conveyor
	Tool spindle (16)	Operation support function	Tool automatic setting
	Tool spindle (20)		Tool setting gauge
	Double angular spindles	Machine management & monitoring function	Tap breakage detector
	Double face spindles		Signal indicator
	Back tool spindle	Tooling parts	Main spindle adapter
	Back adapter		Back spindle adapter
Bar feeder interface	Internal work light		
Coolant system	High pressure pump 750W	Safety and others	Automatic fire extinguisher
	M code oil blow		

NC Functions

Name		Name	
Chasing function	Standard	HRV control	Standard
Continuous thread cutting	Standard	Combined canned cycle	Standard
Manual pulse generator	Standard	Extended program editing	Standard
Memory card I/O interface	Standard	Polar coordinate interpolation	Optional
RS232C I/O interface	Optional	Cylindrical interpolation	Optional
Background editing	Standard	Direct drawing dimension programming	Optional
Run time and parts number display	Standard	Inch/metric selection	Optional
Custom macro	Standard	Drilling canned cycle	Standard
Constant surface speed control	Standard	Rigid tap (main and back)	Standard
Synchronous control (rotation/phase)	Standard	Rigid tap (cross, back tool)	Optional
Tool geometry/wear compensation	Standard	Cut-off detection (differential rate)	Standard
Programmable data input	Standard	Spindle speed fluctuation detection	Standard
Chamfering and corner R	Standard	Abnormal load detection	Optional
Tool nose radius compensation	Standard		

Standard Machine Specifications

Name		SS26	SS32	SS32L
Machining range & capacity	Working barstock diameter	$\phi 8$ to $\phi 26$ mm	$\phi 8$ to $\phi 32$ mm	
	Max. workpiece length	270 mm (rotary guide bushing)* 50 mm (Guide-bushing-less type)*	320 mm (rotary guide bushing)*	70 mm (Guide-bushing-less)
	Main spindle max. drilling dia.	$\phi 12$ mm		$\phi 10$ mm
	Main spindle max. tapping dia.	M10		
	Back spindle max. chucking dia.	$\phi 26$ mm	$\phi 32$ mm	
	Back spindle max. drilling dia.	$\phi 10$ mm		
	Back spindle max. tapping dia.	M8		
	Tool spindle max. drilling dia.	$\phi 8$ mm		
	Tool spindle max. tapping dia.	M6		
	Tool spindle max. slitting cutter dia.	$\phi 45$		
Machine Capability	Main spindle speed	200 to 10,000 min ⁻¹	200 to 8,000 min ⁻¹	
	Back spindle speed	200 to 10,000 min ⁻¹	200 to 8,000 min ⁻¹	
	Rotary guide bushing speed*	200 to 8,000 min ⁻¹		
	Tool spindle speed	200 to 5,000 min ⁻¹		
	Total number of tools	24 (standard)		
	Tool size	16 mm × 16 mm × 100 mm		
	Rapid traverse rate	32 m/min (Z1,Z2,X2) 24 m/min (X1,Y1,Y2)		
	Main spindle indexing function	C1 axis		
Motors	Main spindle	3.7/5.5 kW		
	Back spindle	2.2/3.7 kW		
	Tool spindle	1.0 kW		
	Rotary guide bushing	1.1 kW / 3.7 kW		
	X1, X2, Z1, Z2, Y2	0.75 kW (Y1: 1.0 kW)		
	Coolant pump	0.39/0.62 kW (50/60 Hz)		
	Lubricating oil pump	3 W		
Power supply and others	Net weight	3,400 kg		
	Power source requirement	19 kVA		
	Air pressure	0.4 MPa or higher		
	Air discharge rate	40 NL/min		
	Coolant tank capacity	200 L		
	Width x Depth x Height	2,020 × 1,675 × 2,020		

*Optional Note 1: The machining capacity given above may vary depending on the material to be cut or machining conditions. (Numeric values given above are for S45C)
 Note 2: When the guide-bushless kit is attached, machining capabilities depends on the material and the conditions of cutting.

Standard NC Specifications

Name	SS26	SS32	SS32L
NC unit	FANUC 32i-B		
Axis name	X1, Z1, Y1, X2, Z2, Y2, C1		
Least input increment	0.001 mm (diametral designation for X1, X2 axes)		
Least command increment	X1, X2: 0.0005 mm Other axes: 0.001 mm		
Maximum programmable value	±8 digits		
Interpolation function	Linear/circular		
Rapid traverse rate	32 m/min (X1, Y1, Y2: 24 m/min)		
Cutting feedrate	1 - 6,000 mm/min		
Feedrate override	0 - 150%, 10% step		
Dwell	G04, 0 - 99999.99		
Absolute/incremental command	X, Z, Y, C: Absolute U, W, V, H: Incremental		
Tool offset value	±6 digits		
Number of tool offsets	99		
LCD/MDI	10.4" color LCD		
Part program storage capacity	64 kbyte (equivalent to 80 m punch tape)		
Number of registrable programs	63		
Miscellaneous function	Main: M5 digits Back: M3 digits		
Spindle function	S5 digits		
Tool function	T4 digits		

Tooling zone

SS26/SS32/SS32L

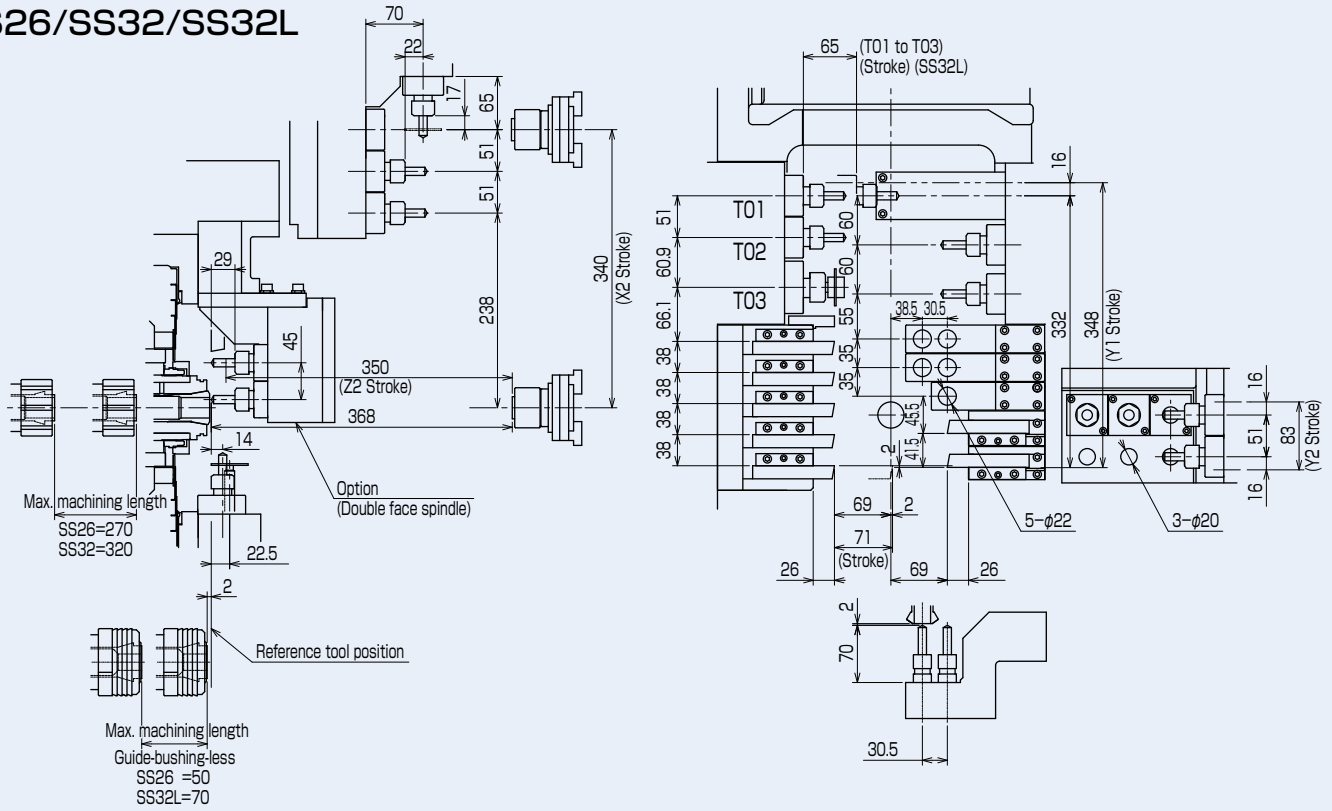

Appearance

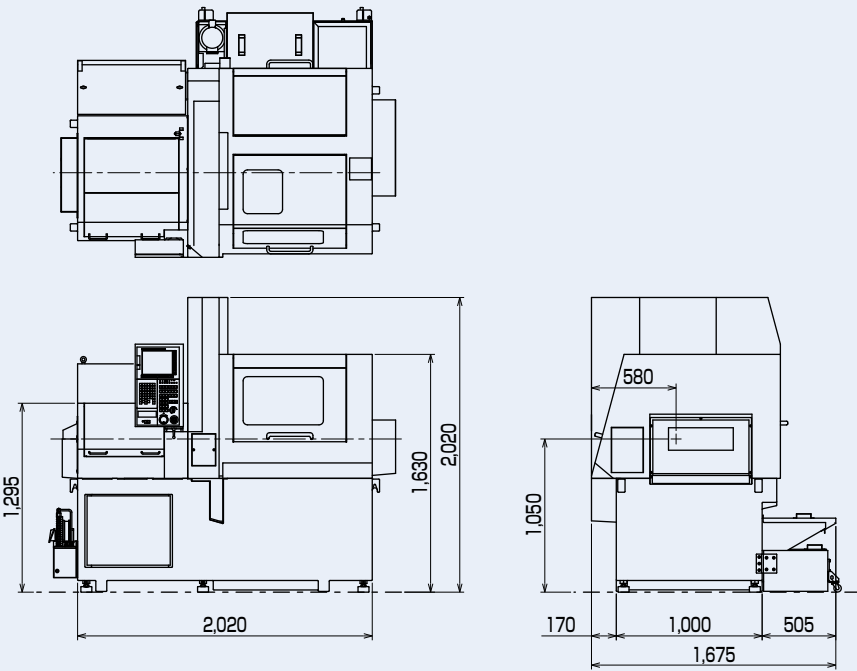

Export permission by the Japanese Government may be required for exporting our products in accordance with the Foreign Exchange and Foreign Trade Law. Please contact our sales office before exporting our products.

The specifications of this catalogue are subject to change without prior notice.



TSUGAMI CORPORATION

12-20, TOMIZAWA-CHO, NIHONBASHI,
CHUO-KU, TOKYO 103-0006, JAPAN
Phone : 03-3808-1172
Facsimile : 03-3808-1175